



ROCKMORE
INTERNATIONAL
Rock Drilling Tools



X TUBELESS X

DTH HAMMER

ROK 60T-360T

IR 360 Bit Shank
Tubeless (Bit without Blow Tube)

Recommended Bit Diameter
155 - 178mm [6.1" - 7.0"]

TUBELESS DESIGN (UTILIZES BIT WITHOUT BLOW TUBE / FOOT VALVE)

Features:

- Ultra High Performance Design
- Tubeless (utilizes Bit without Blow Tube / Foot Valve), eliminating breakage of plastic parts
- Operates With Standard IR 360 Shank Design Without Blow Tube / Foot Valve
- High Efficiency Against Large Volumes of Water
- Integrated SonicFlow Technology
- Patented Innovations
- Superior Penetration Rates
- Reduced Number of Components
- Easy Assembly / Maintenance
- Advanced Materials / Heat-Treatment
- Extended Service Life



Standard IR 360 Bit Shank without Blow Tube / Foot Valve

Rockmore's ROK 60T DTH hammer utilizes a bit without a plastic blow tube / foot valve. The corresponding 360T bit shank operates with no blow tube / foot valve. To operate the hammer with a standard IR 360 bit shank, simply remove the blow tube / foot valve.

SonicFlow Technology greatly improves the air flow characteristics within the ROK hammer and ensures that the high pressure air paths are optimized to deliver greater energy to the piston. This is achieved by incorporating scientific air flow concepts in the design of the hammer and its various components such as the Top Sub, Piston, and Wear Sleeve. This technology results in more impact energy to the bit and produces higher penetration rates and better overall hammer performance.



Applications:

- Mining / Blast Hole
- Exploration
- Construction / Quarry
- Geothermal
- Water-Well

Innovative Design Features

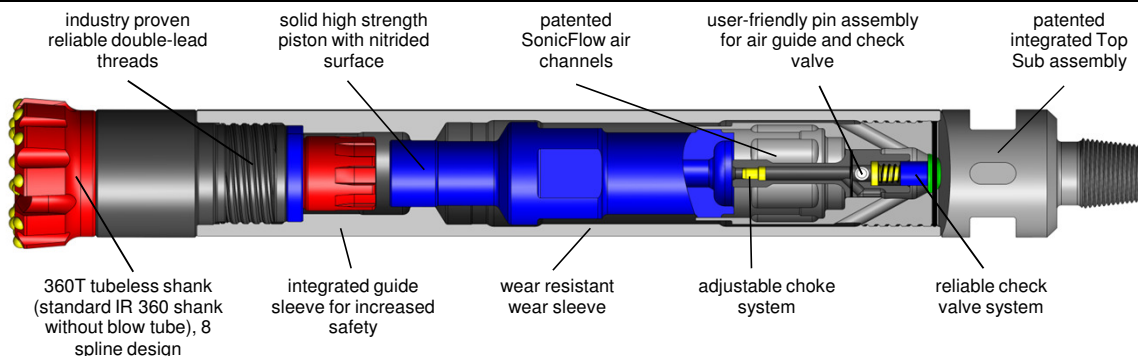

ROCKMORE International, Inc. 10065 S.W. Commerce Circle; Wilsonville, OR 97070, USA
Tel: +1-503-682-1001; Fax: +1-503-682-1002; info@rockmore-intl.com

ROCKMORE International GmbH Collini - Strasse 2; A-8750 Judenburg - Austria
Tel: +43 3572 86 300-0; Fax: +43 3572 84 179; austria@rockmore-intl.at

www.rockmore-intl.com

Rev. 6-12-24

X TUBELESS X**ROCKMORE
INTERNATIONAL**

Rock Drilling Tools

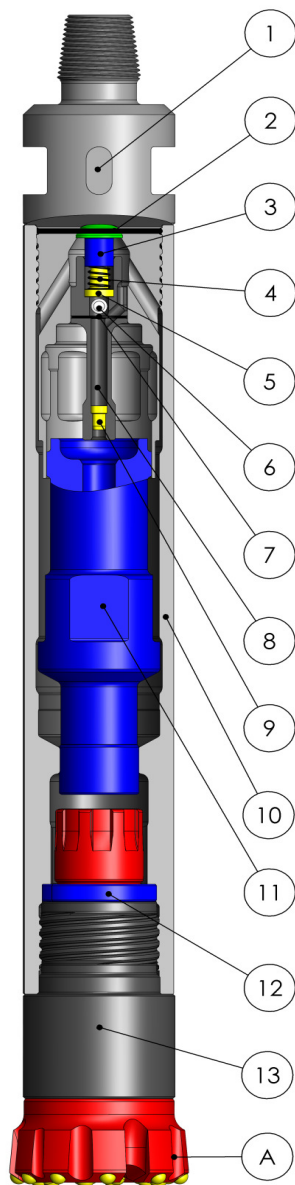
SONICFLOW**Integrated SonicFlow
Technology****ROK 60T-360T**

Patented

Parts List

Item	Part Number	Description
	ROK60T-360T-001	DTH Hammer, 60T, 360T, 3-1/2" API Reg Pin, Tubeless (Bit without Blow Tube / Foot Valve)
3	CV-002	Check Valve, Rubber
	ROK60T-360T-003	DTH Hammer, 60T, 360T, 3-1/2" API Reg Pin, Tubeless (Bit without Blow Tube / Foot Valve)
3	CV-010	Check Valve, Delrin
1	600TS-001	Top Sub, 3-1/2" API Reg Pin - includes o-ring
2	R2-349	O-Ring, 4.475" X 0.210"
4	SP-001	Spring
5	SR-002	Spring Rest
6	PN-001	Pin, 0.625" Dia, 4.5" L
7	R2-135	O-Ring, 1.925" X 0.103"
8	AG-001	Air Guide - includes o-ring and choke
9	CH-005	Blank Choke, Nylon
10	600TWS-001	Wear Sleeve
11	PT-017-C	Piston, Carburized
12	BR-018	Bit Retainer Ring
13	600DS-004	Driver Sub
A	DTH Bit	360T Tubeless Shank (Standard IR 360 without blow tube)
	CHSET-002	Choke Set, Nylon, 1 each of CH-005 - 0" (0mm), CH-006 - 1/16" (2mm), CH-007 - 1/8" (3mm), CH-008 - 3/16" (5mm)

Operating Parameters

Air Pressure	Air Consumption
10.4 Bar [150 PSI]	8.6 m ³ /min [305 SCFM]
17.2 Bar [250 PSI]	19.5 m ³ /min [689 SCFM]
24.1 Bar [350 PSI]	32.4 m ³ /min [1145 SCFM]
Oil consumption:	0.2 l/hr per 3.0 m ³ /min [1/3 pint/hr per 100 cfm]
Recommended rotation speed:	15 r/min to 60 r/min
Minimum diameter difference between wear sleeve and bit:	12 mm [0.47"]

Technical Specifications

Bit shank type	360T Tubeless Shank (IR 360 without Blow Tube / Foot Valve)
Recommended bit diameter, mm [in]	155 to 178 [6.1 to 7.0]
Outside diameter, mm [in]	142 [5.6]
Wear sleeve discard diameter, mm [in]	130 [5.1]
Wrench flat size on Top Sub, mm [in]	95 [3.74]
Effective Length without drill bit, mm [in]	1057 [41.6]
Weight without drill bit, kg [lbs]	86.2 [190.0]

ROCKMORE International, Inc. 10065 S.W. Commerce Circle; Wilsonville, OR 97070, USA
Tel: +1-503-682-1001; Fax: +1-503-682-1002; info@rockmore-intl.com

ROCKMORE International GmbH Collini - Strasse 2; A-8750 Judenburg - Austria
Tel: +43 3572 86 300-0; Fax: +43 3572 84 179; austria@rockmore-intl.at

www.rockmore-intl.com

Rev. 6-24-26