



**ROCKMORE**  
INTERNATIONAL  
Rock Drilling Tools



**X TUBELESS X**

**DTH HAMMER**

**ROK 550T**

QL5/QL50 Bit Shank  
Tubeless (Bit without Blow Tube)  
Slim Line Diameter

Recommended Bit Diameter  
133 - 146mm [5.25" - 5.75"]

TUBELESS DESIGN (UTILIZES BIT WITHOUT BLOW TUBE / FOOT VALVE)

**Features:**

- Ultra High Performance Design
- Tubeless (utilizes Bit without Blow Tube / Foot Valve) eliminating breakage of plastic parts
- Operates With Standard QL5/QL50 Shank Design Without Blow Tube / Foot Valve
- High Efficiency Against Large Volumes of Water
- Integrated SonicFlow Technology
- Patented Innovations
- Superior Penetration Rates
- Reduced Number of Components
- Easy Assembly / Maintenance
- Advanced Materials / Heat-Treatment
- Extended Service Life



**Standard QL5/QL50 Bit shank without Blow Tube / Foot Valve**

Rockmore's ROK 550T DTH hammer utilizes a bit without a plastic blow tube / foot valve. The corresponding QL5T bit shank operates with no blow tube / foot valve. To operate the hammer with a standard QL5/QL50 bit shank, simply remove the blow tube / foot valve.

**SonicFlow Technology** greatly improves the air flow characteristics within the ROK hammer and ensures that the high pressure air paths are optimized to deliver greater energy to the piston. This is achieved by incorporating scientific air flow concepts in the design of the hammer and its various components such as the Top Sub, Piston, and Wear Sleeve. This technology results in more impact energy to the bit and produces higher penetration rates and better overall hammer performance.



**Applications:**

- Mining / Blast Hole
- Environmental
- Construction / Quarry
- Exploration
- Water-Well
- Geothermal

**Innovative Design Features**

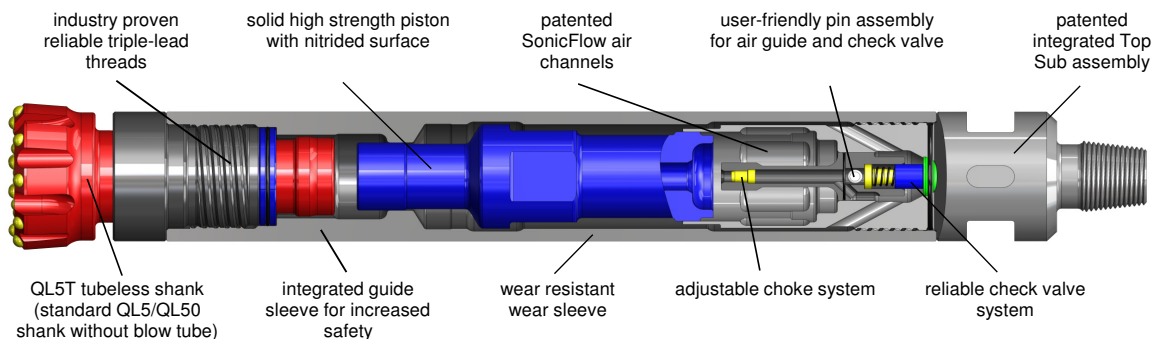

ROCKMORE International, Inc. 10065 S.W. Commerce Circle; Wilsonville, OR 97070, USA  
Tel: +1-503-682-1001; Fax: +1-503-682-1002; info@rockmore-intl.com

ROCKMORE International GmbH Collini - Strasse 2; A-8750 Judenburg - Austria  
Tel: +43 3572 86 300-0; Fax: +43 3572 84 179; austria@rockmore-intl.at

www.rockmore-intl.com

Rev. 6-12-24

**X TUBELESS X****ROCKMORE  
INTERNATIONAL**

Rock Drilling Tools

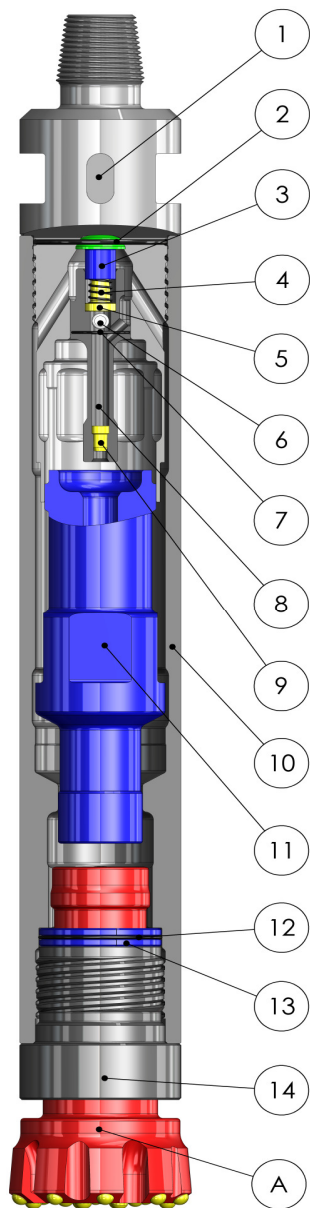
**SONICFLOW****Integrated SonicFlow  
Technology****ROK 550T**

Patented

**Parts List**

Item	Part Number	Description
	ROK550T-003	DTH Hammer, 550T, QL5T, 3-1/2" API Reg Pin, Tubeless (Bit without Blow Tube / Foot Valve), Slim Line
1	500TS-014	Top Sub, 3-1/2" API Reg Pin, Slim Line - <i>includes o-ring</i>
2	R2-342	O-Ring, 3.600" X 0.210"
3	CV-002	Check Valve, Rubber
4	SP-001	Spring
5	SR-002	Spring Rest
6	PN-003	Pin, 0.625" Dia, 3.5" L
7	R2-135	O-Ring, 1.925" X 0.103"
8	AG-001	Air Guide - <i>includes o-ring and choke</i>
9	CH-005	Blank Choke, Nylon
10	500WS-013	Wear Sleeve, Slim Line
11	PT-028-C	Piston, Carburized
12	R2-234	O-Ring, 2.984" X 0.139"
13	BR-014	Bit Retainer Ring - <i>includes o-ring</i>
14	500DS-007	Driver Sub, Slim Line
A	DTH Bit	QL5T Tubeless Shank (Standard QL5/QL50 without blow tube)
	CHSET-002	Choke Set, Nylon, 1 each of CH-005 - 0" (0mm), CH-006 - 1/16" (2mm), CH-007 - 1/8" (3mm), CH-008 - 3/16" (5mm)

**Operating Parameters**

Air Pressure	Air Consumption
10.4 Bar [150 PSI]	7.3 m <sup>3</sup> /min [259 SCFM]
17.2 Bar [250 PSI]	16.6 m <sup>3</sup> /min [587 SCFM]
24.1 Bar [350 PSI]	25.2 m <sup>3</sup> /min [890 SCFM]
Oil consumption:	0.2 l/hr per 3.0 m <sup>3</sup> /min [1/3 pint/hr per 100 cfm]
Recommended rotation speed:	20 r/min to 70 r/min
Minimum diameter difference between wear sleeve and bit:	10 mm [0.39"]

**Technical Specifications**

Bit shank type	QL5T Tubeless Shank (QL5/QL50 without Blow Tube / Foot Valve)
Recommended bit diameter, mm [in]	133 to 146 [5.25 to 5.75]
Outside diameter, mm [in]	119 [4.7]
Wear sleeve discard diameter, mm [in]	109 [4.3]
Wrench flat size on Top Sub, mm [in]	89 [3.5]
Effective Length without drill bit, mm [in]	953 [37.5]
Weight without drill bit, kg [lbs]	55.6 [122.5]

ROCKMORE International, Inc. 10065 S.W. Commerce Circle; Wilsonville, OR 97070, USA  
 Tel: +1-503-682-1001; Fax: +1-503-682-1002; info@rockmore-intl.com

ROCKMORE International GmbH Collini - Strasse 2; A-8750 Judenburg - Austria  
 Tel: +43 3572 86 300-0; Fax: +43 3572 84 179; austria@rockmore-intl.at

www.rockmore-intl.com

Rev. 6-24-26