



ROCKMORE
INTERNATIONAL
Rock Drilling Tools



3-1/2" API Reg Pin

DTH HAMMER

ROK 600Q-002

Recommended Bit Diameter
152 - 178mm [6.0 - 7.0 in]



Features:

- High Performance Design
- Integrated SonicFlow Technology
- Patent Pending Innovations
- Superior Penetration Rates
- Reduced Number of Components
- Easy Assembly / Maintenance
- Advanced Materials / Heat-Treatment
- Extended Service Life

Applications:

- Mining / Blast Hole
- Construction / Quarry
- Water-Well

SonicFlow Technology greatly improves the air flow characteristics within the ROK hammer and ensures that the high pressure air paths are optimized to deliver greater energy to the piston. This is achieved by incorporating scientific air flow concepts in the design of the hammer and its various components such as the Top Sub, Piston, and Wear Sleeve. This technology results in more impact energy to the bit and produces higher penetration rates and better overall hammer performance.



Innovative Design Features

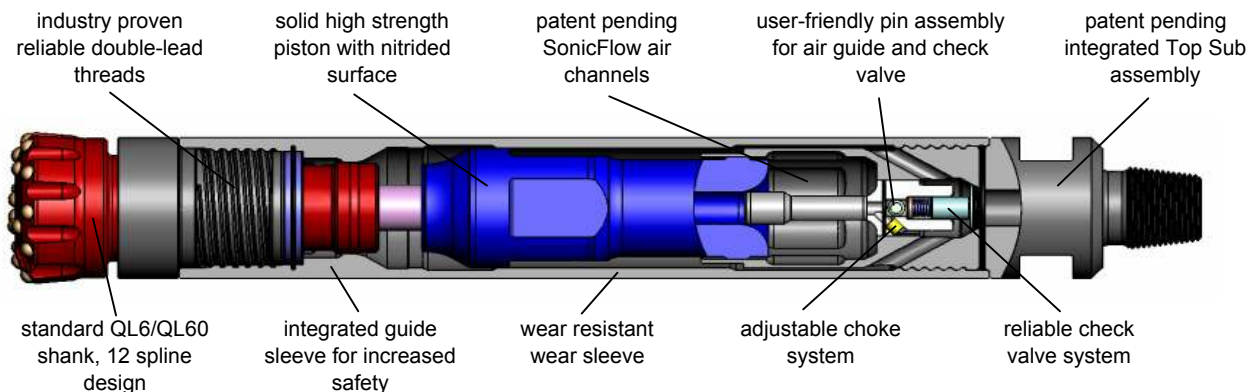

ROCKMORE International, Inc. 10065 S.W. Commerce Circle; Wilsonville, OR 97070, USA
Tel: +1-503-682-1001; Fax: +1-503-682-1002; info@rockmore-intl.com

ROCKMORE International GmbH Gussstahlwerkstrasse 21; A-8750 Judenburg - Austria
Tel: +43 3572 86 300-0; Fax: +43 3572 84 179; austria@rockmore-intl.com

www.rockmore-intl.com

Rev. 3-16-09

**Integrated SonicFlow
Technology**

ROK 600Q-002

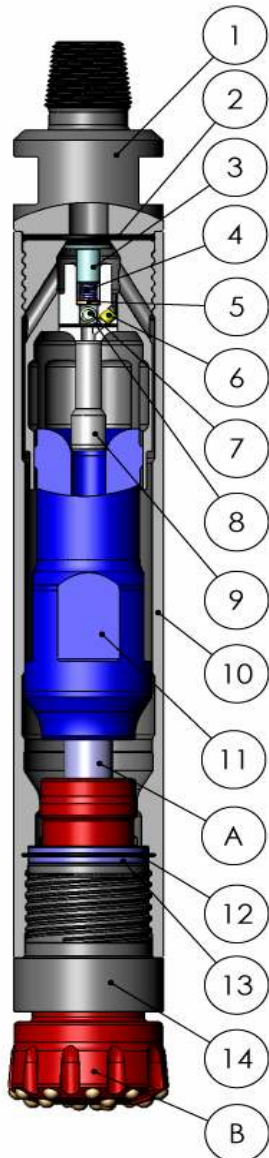

Patent Pending

Parts List

Item	Part Number	Description
	ROK 600Q-002	DTH Hammer, 600Q, QL6/QL60, 3-1/2 in API Reg Pin
1	600TS-001	Top Sub, 3-1/2 in API Reg Pin
2	R2-349	O-Ring, 4.475 in X 0.210 in
3	CV-001	Check Valve
4	SP-001	Spring
5	SR-002	Spring Rest
6	CH-001	Choke
7	PN-001	Pin, 0.625 in Dia, 4.5 in L
8	R2-135	O-Ring, 1.925 in X 0.103 in
9	AG-001	Air Guide
10	600WS-002	Wear Sleeve, with Integrated Guide Sleeve
11	PT-001	Piston
A	BTQL6-1014	QL6/QL60 Blow Tube
12	R2-236	O-Ring, 3.234 in X 0.139 in
13	BR-001	Bit Retainer Ring
14	600DS-001	Driver Sub
B	DTH Bit	QL6/QL60 Shank

Operating Parameters

Air Pressure	Air Consumption
10.4 Bar [150 PSI]	10.6 m ³ /min [386 SCFM]
17.2 Bar [250 PSI]	19.8 m ³ /min [720 SCFM]
24.1 Bar [350 PSI]	29.1 m ³ /min [1056 SCFM]
Oil consumption at 24.1 Bar (350 PSI):	0.7 l/hr [0.2 gallon/hr]
Recommended rotation speed:	15 r/min to 60 r/min
Minimum diameter difference between wear sleeve and bit:	12 mm [0.47 in]

Technical Specifications

Standard Top Sub	3-1/2" API Reg Pin
Bit shank type	QL6/QL60
Recommended bit diameter, mm [in]	152 to 178 [6.0 to 7.0]
Outside diameter, mm [in]	141.5 [5.6]
Wear sleeve discard diameter, mm [in]	130 [5.1]
Wrench flat size on Top Sub, mm [in]	95 [3.8]
Length without drill bit, mm [in]	1013 [39.9]
Weight without drill bit, kg [lbs]	76 [168.0]

ROCKMORE
International, Inc.
10065 S.W. Commerce Circle
Wilsonville, OR 97070, USA
Tel: +1-503-682-1001
Fax: +1-503-682-1002
info@rockmore-intl.com

ROCKMORE
International GmbH
Gussstahlwerkstrasse 21
A-8750 Judenburg - Austria
Tel: +43 3572 86 300-0
Fax: +43 3572 84 179
austria@rockmore-intl.com