



ROCKMORE
INTERNATIONAL
Rock Drilling Tools



2-3/8" API Reg Box

DTH HAMMER

ROK 400-005

Recommended Bit Diameter
110 - 125mm [4.3 - 4.9 in]



Features:

- High Performance Design
- Integrated SonicFlow Technology
- Patent Pending Innovations
- Superior Penetration Rates
- Reduced Number of Components
- Easy Assembly / Maintenance
- Advanced Materials / Heat-Treatment
- Extended Service Life

SonicFlow Technology greatly improves the air flow characteristics within the ROK hammer and ensures that the high pressure air paths are optimized to deliver greater energy to the piston. This is achieved by incorporating scientific air flow concepts in the design of the hammer and its various components such as the Top Sub, Piston, and Wear Sleeve. This technology results in more impact energy to the bit and produces higher penetration rates and better overall hammer performance.



Applications:

- Mining / Blast Hole
- Environmental
- Geothermal
- Construction / Quarry
- Exploration

Innovative Design Features

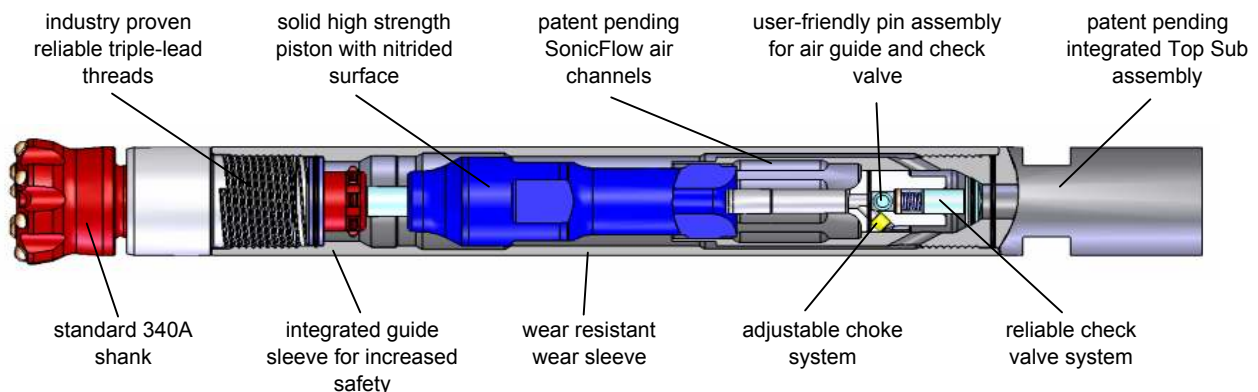

ROCKMORE International, Inc. 10065 S.W. Commerce Circle; Wilsonville, OR 97070, USA
Tel: +1-503-682-1001; Fax: +1-503-682-1002; info@rockmore-intl.com

ROCKMORE International GmbH Gussstahlwerkstrasse 21; A-8750 Judenburg - Austria
Tel: +43 3572 86 300-0; Fax: +43 3572 84 179; austria@rockmore-intl.com

www.rockmore-intl.com

Rev. 3-16-09

**Integrated SonicFlow
Technology**

ROK 400-005

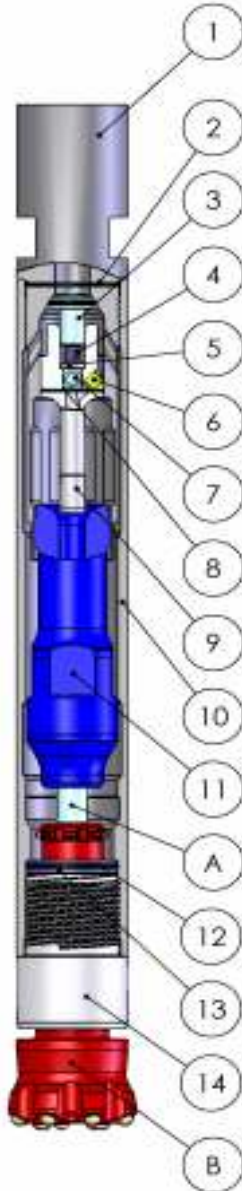

Patent Pending

Parts List

Item	Part Number	Description
	ROK 400-005	DTH Hammer, 400, 340A, 2-3/8 in API Reg Box
1	400TS-005	Top Sub, 2-3/8 in API Reg Box
2	R2-234	O-Ring, 2.984 in X 0.139 in
3	CV-001	Check Valve
4	SP-001	Spring
5	SR-002	Spring Rest
6	CH-001	Choke
7	PN-002	Pin, 0.625 in Dia, 3.0 in L
8	R2-135	O-Ring, 1.925 in X 0.103 in
9	AG-002	Air Guide
10	400WS-001	Wear Sleeve
11	PT-003	Piston
A	BT340A-1003	340A Blow Tube
12	R2-229	O-Ring, 2.359 in X 0.139 in
13	BR-003	Bit Retainer Ring
14	400DS-001	Driver Sub
B	DTH Bit	340A Shank

Operating Parameters

Air Pressure	Air Consumption
10.4 Bar [150 PSI]	5.8 m ³ /min [210 SCFM]
17.2 Bar [250 PSI]	10.4 m ³ /min [378 SCFM]
24.1 Bar [350 PSI]	15.3 m ³ /min [556 SCFM]
Oil consumption at 24.1 Bar (350 PSI):	0.4 l/hr [0.1 gallon/hr]
Recommended rotation speed:	25 r/min to 80 r/min
Minimum diameter difference between wear sleeve and bit:	10 mm [0.40 in]

Technical Specifications

Standard Top Sub	2-3/8" API Reg Box
Bit shank type	340A
Recommended bit diameter, mm [in]	110 to 125 [4.3 to 4.9]
Outside diameter, mm [in]	98 [3.9]
Wear sleeve discard diameter, mm [in]	89 [3.5]
Wrench flat size on Top Sub, mm [in]	64 [2.5]
Length without drill bit, mm [in]	898 [35.4]
Weight without drill bit, kg [lbs]	32.1 [70.8]

ROCKMORE
International, Inc.
10065 S.W. Commerce Circle
Wilsonville, OR 97070, USA
Tel: +1-503-682-1001
Fax: +1-503-682-1002
info@rockmore-intl.com

ROCKMORE
International GmbH
Gussstahlwerkstrasse 21
A-8750 Judenburg - Austria
Tel: +43 3572 86 300-0
Fax: +43 3572 84 179
austria@rockmore-intl.com